

REACH STACKER

SAFETY AND LICENCE GUIDE



Training support material for:

TLILIC0011
Licence to operate
a reach stacker
(greater than 3 tonnes
capacity)

Produced by:



PICTURE BASED. PLAIN ENGLISH. LEARNING MADE EASY.

CONTENTS

Introduction to reach stackers	5
High risk licensing and the law	9
Plan work/task	21
Prepare for work/task	61
Perform work/task	87
Pack up	105

INTRODUCTION TO REACH STACKERS

What is a reach stacker (container handler)?

A reach stacker is a type of heavy-duty machine used in ports and warehouses to lift and move large shipping containers. It has a long arm (or boom) that can extend and retract, allowing it to reach containers stacked several rows deep. The reach stacker picks up containers from ships or storage areas and stacks them in organized rows or moves them to trucks or trains for transportation. Essentially, it's like a big, powerful reach stacker designed specifically for handling shipping containers.



Parts of a reach stacker

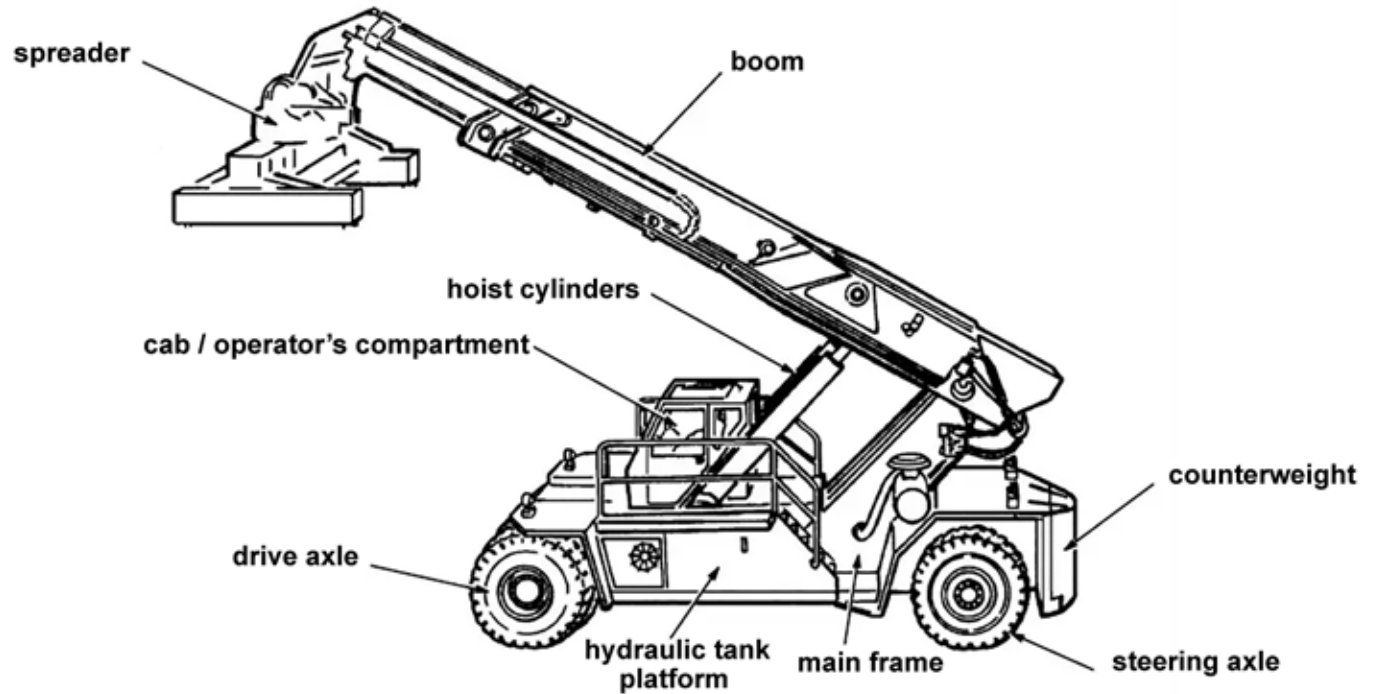

You can find information about a reach stacker in the following places:



In the operator's manual

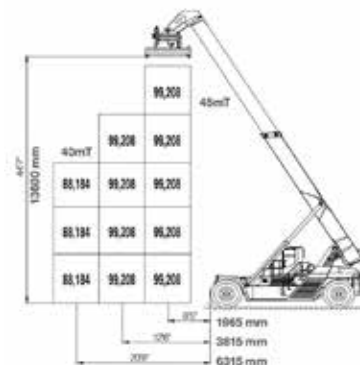

On load charts



In manufacturer's specification such as decals



Marked or labelled on the reach stacker

ELEMENT 1

PLAN WORK/TASK

Task requirements

Before operating the reach stacker you must know what the work task requires you to do.

Task requirements may be given to you verbally, in writing or electronically. They may be called work orders or something similar. If you are unclear about the requirements you should always speak to a supervisor or relevant person.

When the task requirements are known, you will be able to consider and plan for other important things such as:

Communication needed.



Attachment method (for the load).



Where will you do the lift? What do you need to do?



What equipment do you need? Is the equipment available?



How much can a reach stacker lift?

Maximum Rated Capacity (MRC):

MRC refers to the absolute maximum load or weight that a piece of equipment, such as a reach stacker, can handle as specified by the manufacturer.

It is determined based on engineering calculations, stress testing, and compliance with safety standards.

MRC represents the maximum theoretical capacity of the equipment under ideal conditions, assuming perfect operation and no external factors affecting performance.

Work Load Limit (WLL):

WLL is a practical limit set to ensure safe operation of the equipment in real-world conditions.

It considers various factors such as environmental conditions, dynamic loading (movement, acceleration, deceleration etc), equipment wear and tear, and operational considerations.

WLL may vary depending on the specific task, conditions, and regulations, and it is often determined through risk assessments and operational experience.

The WLL is often set lower than the MRC to provide a safety margin and account for operational variables.



It is the responsibility of the reach stacker operator to find out the weight of a load.

Shipping containers

The data plate on a container typically provides information about its weight, including the tare weight (empty weight) and gross weight (weight including cargo). This information is crucial for the reach stacker operator to ensure that the container is within the equipment's rated capacity and to prevent overloading.

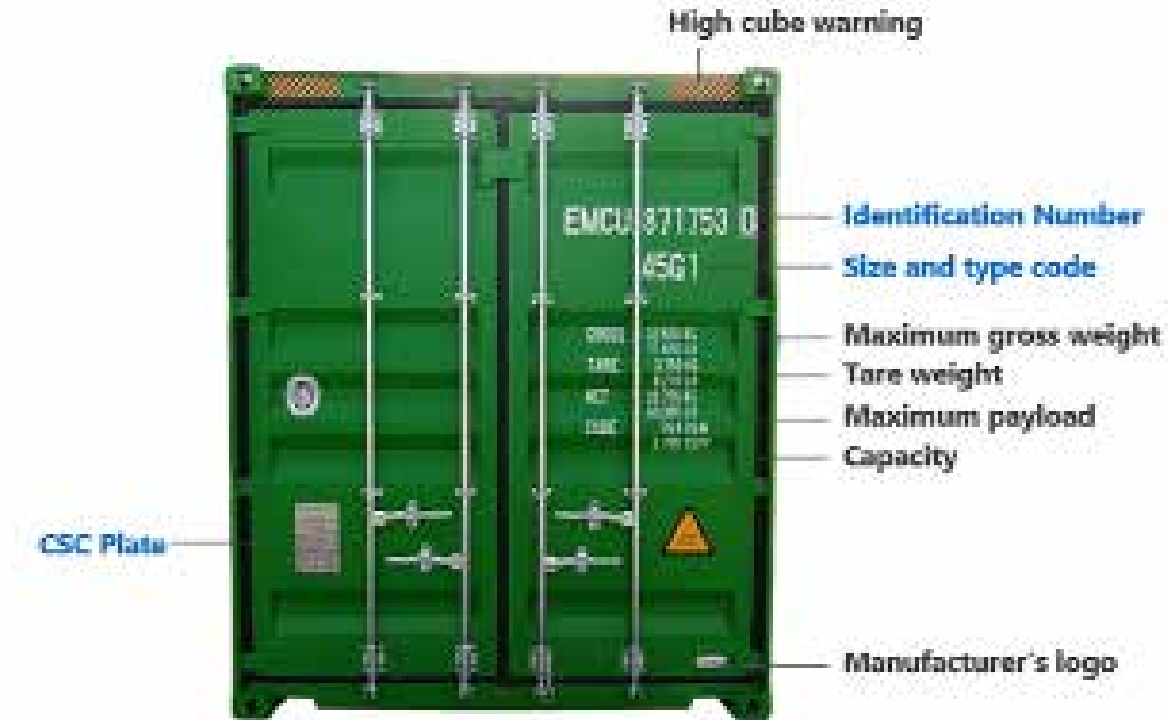

Path of travel

Inspecting the work area also helps you to determine the most appropriate pathways for operating the reach stacker and for moving and placing loads.

When planning your path of travel you should consider some of the following things:

When should you sound the horn?

Will you need to reverse?

Where will you have to stop?

Where should you slow down?

What is the speed limit?

Are there places the reach stacker can't go?

Where will there be pedestrians?

Is there a suitable area to place the load?



Choosing the path to operate the reach stacker

You need to plan the path you will take when operating the reach stacker.

Appropriate paths for operating the reach stacker

This involves considering factors such as the layout of the area, obstacles, safety regulations, and efficiency.

Moving and placing container/s in work area

This refers to the actions of transporting and positioning containers within the designated work area using the reach stacker. It involves lifting containers from one location and carefully placing them in another location, often within a storage yard or loading area.

Assess and determine in accordance with workplace procedures

This part emphasises that the evaluation and decision-making process regarding the paths for operating the reach stacker and moving containers is done following the established guidelines, rules, and protocols of the workplace. It underscores the importance of adhering to safety protocols, operational guidelines, and any other relevant procedures to ensure efficient and safe operations.

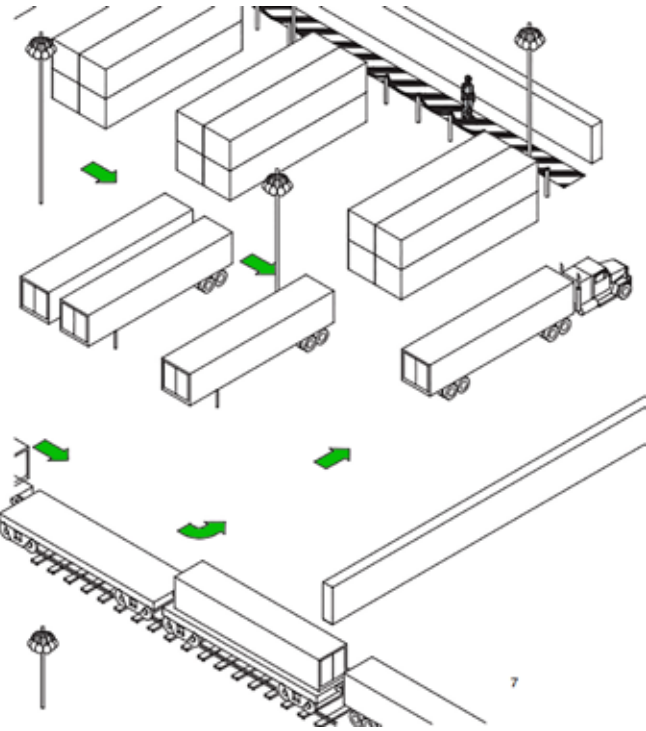

choose path carefully

Hazard versus risk

What is the difference?

Different hazards and risks emerge constantly—sometimes instantly.

Hazard

A hazard is any thing or any situation which could injure or harm you.

In other words, it is anything that can hurt you.



Risk

A risk is the chance of a hazard causing harm such as injury, illness or even death.

In other words, how likely it is that somebody or something may be harmed by the hazard.



Risk control

You should apply risk control measures:

- before you start work
- as soon as you spot a hazard while working.

Risk management is made up of the following five steps.

1. **Identifying hazards.**
2. **Assessing the risk involved.**
3. **Talking and reporting to other workers.**
4. **Controlling the hazards to lower the risk.**
5. **Reviewing the action you have taken.**



Check for hazards

There are a lot of hazards and risks on work sites that you need to be aware of. Hazards can cause accidents, injuries and even death.

Hazards and hazard controls need to be considered when planning work.

The work site should be inspected by looking for hazards and risks that exist:

- Above eye level (in the air)
- At eye level
- Below eye level (on the ground).

You should **always** follow workplace procedures for conducting site inspections.

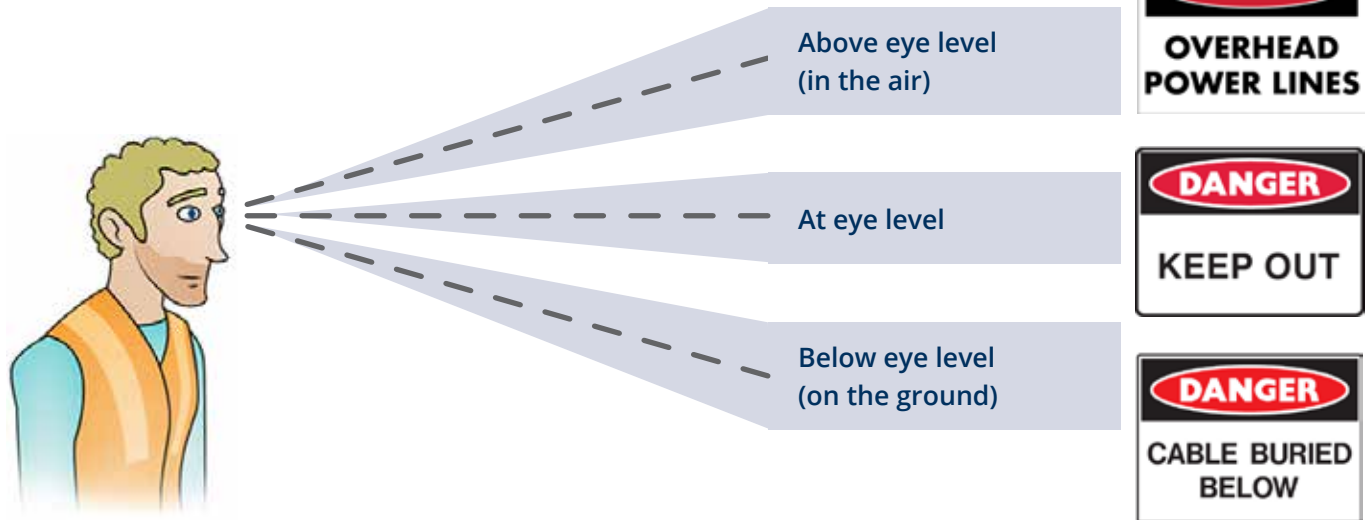

Hazard control measures

When operating a reach stacker stacker there are a number of ways to protect the safety of pedestrians, other workers, vehicles or mobile plant. Some ways to do this include:

Pedestrian or vehicle exclusion zones



Traffic management plan



Warning signs

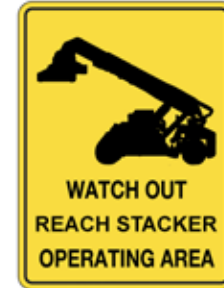

Safety barriers and bollards



Speed limit signs



Hazard lights (flashing) or horns

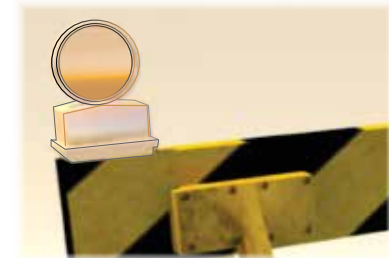

Note: If your work involves a public road you should contact your local authority for the relevant traffic management requirements and guidelines. In some states/territories you may need to be licensed to control traffic.

Overhead powerlines

Always check for overhead powerlines. Make sure your reach stacker and anything you are carrying does not come into contact with powerlines.

There is a National Australian Standard number AS 2550.1 – which outlines the distances you need to work from powerlines.

If you need to know the voltage of powerlines, you should contact the local power supply company.

**Note:**

Some states have their own rules.

You must always check the distances for your state or territory as they may be different. Some allow a spotter / guide and it may be possible to work closer.

Overhead powerlines on poles (National Standard)

These are usually '**Low Voltage**'. This means powerlines of less than 133KV.

The information below is taken from the National Standard.

Always check the distances for your state or territory, as they may be different.

AS2550.1 Powerline distances

Powerline distances “Look up and live!”

Always check overhead for powerlines and make sure you and any equipment or materials you are using do not come into contact with them.

The safe operating distances for working near powerlines are outlined on the following pages.

A **spotter** is required if you are working between 3 to 6.4 metres from distribution lines on poles.

The term '**spotter**' is defined as a safety observer who is a person competent for the sole task of observing and warning against unsafe approach to overhead powerlines and other electrical apparatus.

In some states or territories a spotter **must be** qualified.

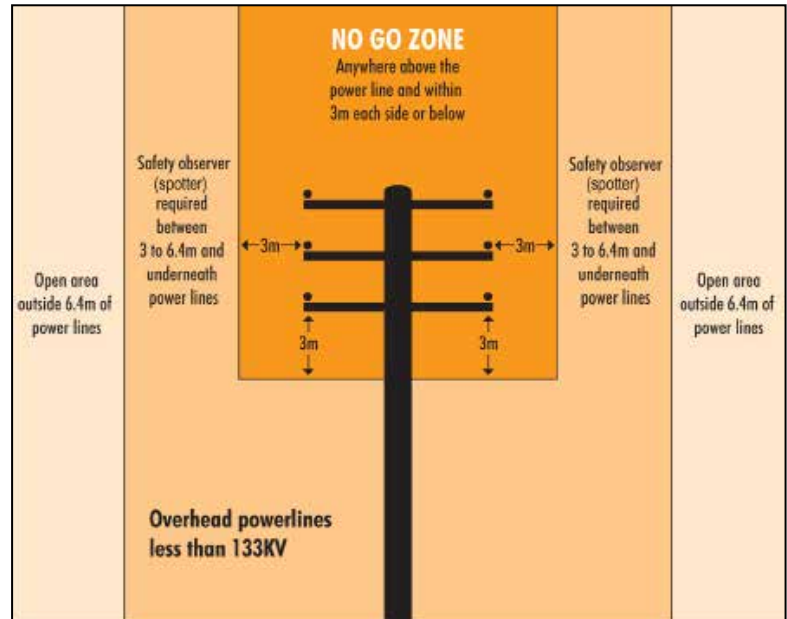

Above is the National Standard. **Always check the distances for your state or territory, as they may be different.**

Overhead powerlines on towers (National Standard)

These are usually **'High Voltage'**. This means powerlines of more than 133KV.

The information below is taken from the National Standard.

Always check the distances for your state or territory, as they may be different.

AS2550.1 Powerline distances

A **spotter** is required if you are working between 8 to 10 metres from transmission lines on **towers**.

The term **'spotter'** is defined as a safety observer who is a person competent for the sole task of observing and warning against unsafe approach to overhead powerlines and other electrical apparatus.

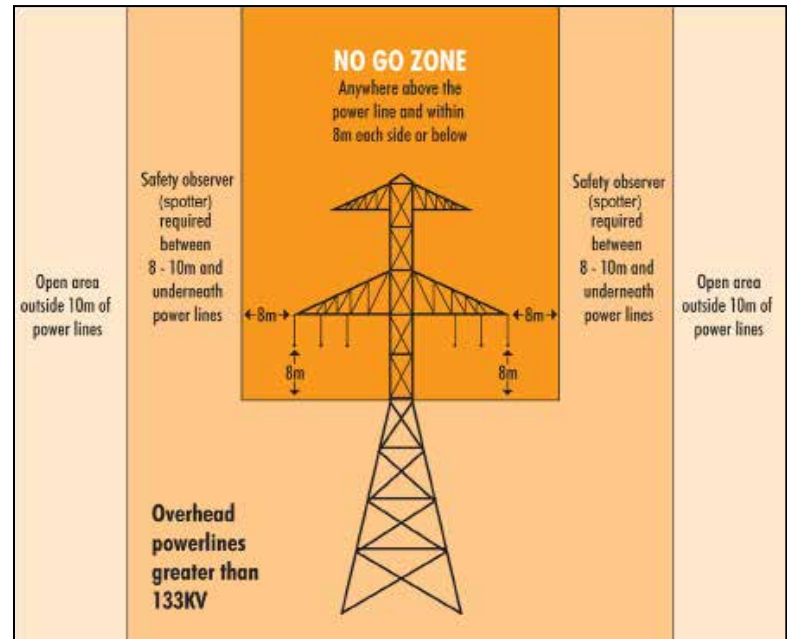

Above is the National Standard. **Always check the distances for your state or territory, as they may be different.**

Personal Protective Equipment (PPE)

The best way to make the workplace safe is to take away hazards altogether. But often you can't do this. This is where Personal Protective Equipment (or PPE) can help.

PPE is clothing or equipment worn on the body to protect you from hazards. PPE will not take away the risk of harm altogether, but it will help keep you safe. These are some examples of PPE.

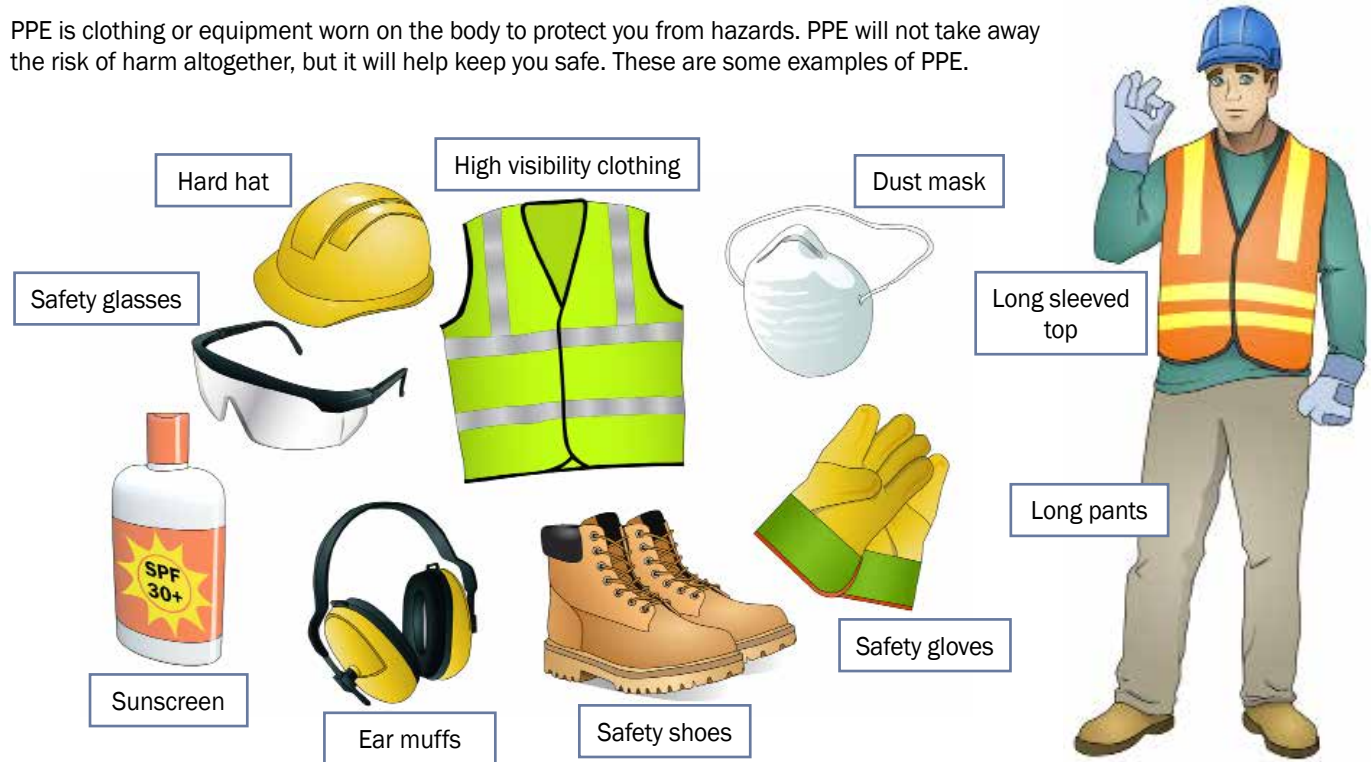

Note: Before starting any work all PPE should be chosen and checked to make sure it is in good working order

Hazard control (continued)

PPE examples

Here are examples of how personal protective equipment can protect you and your work mates:

Safety shoes can protect your feet.



Safety helmet or hard hat can protect your head from falling objects.

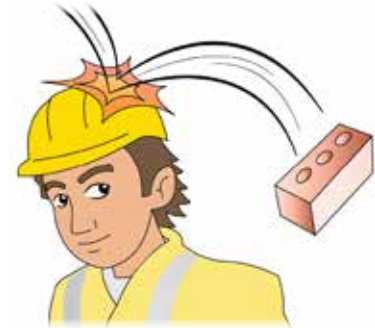

Safety glasses or goggles can protect your eyes from harmful objects.



Dust masks can stop you from breathing in harmful dust.



Traffic management

The best method of controlling this hazard is by completely separating the reach stacker so it cannot come into contact with pedestrians, other vehicles or structures. You need to set up a traffic management plan. Some ways to do this include:

Pedestrian exclusion zones



Vehicle exclusion zones



Warning signs

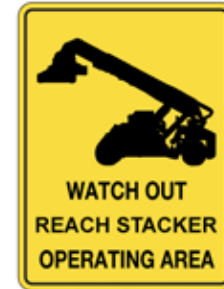

Barriers and bollards



Flag person or traffic controller



Hazard lights (flashing)

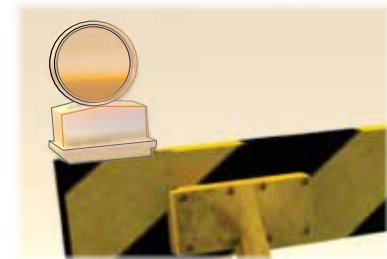

Note: If your work involves a public road you should contact your local authority for the relevant traffic management requirements and guidelines. In some states/territories you may need to be licensed to control traffic.

CHAPTER 2

PREPARE FOR WORK/TASK

Maintain consultation

When preparing for the work task, you must continue to consult with the relevant people as required. This is important to make sure that the work plan is clear, and is consistent with the requirements of the work site and safe work procedures.

Safe work procedures (SWPs)

Safe work procedures (SWPs), which may also be referred to as Standard operating procedures (SOPs) are documents that:

- Tell you about the risks involved in doing a certain work task
- Outline the controls that can be put in place to help you do the task safely
- They are usually written as a set of basic steps for workers to follow.



Access reach stacker safely

Always use three (3) points of contact facing the machine.

For example, use two hands and one foot or two feet and one hand.

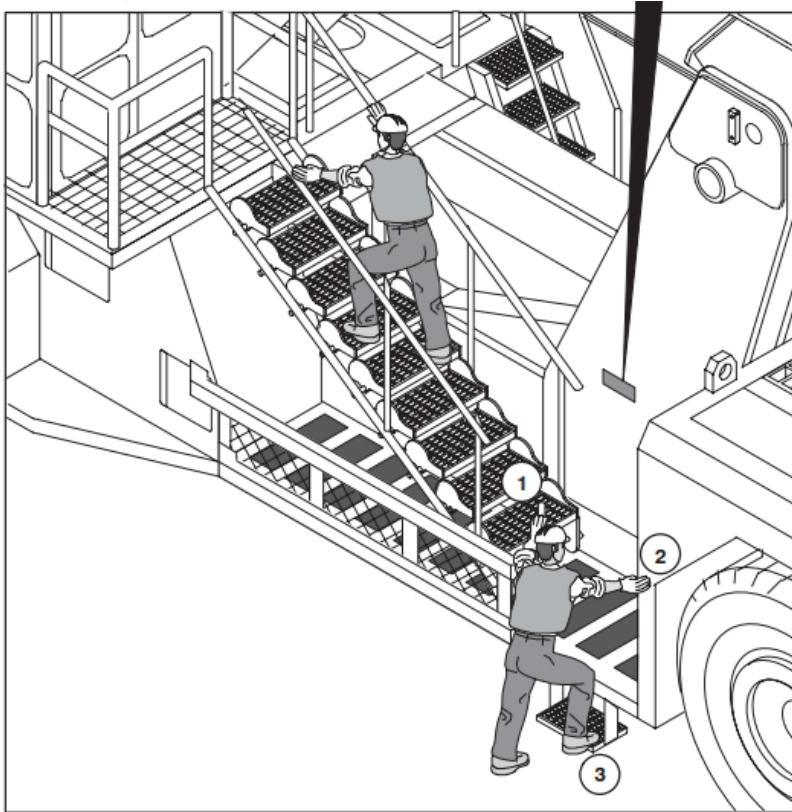

three points of contact

Pre-start reach stacker checks

The operator must do a pre-start check before using a reach stacker. This may also be called a pre-operational check. Pre-start checks involve looking over the reach stacker and making sure it is safe and suitable for the job. You should check:



Visual Inspection:

Look for any visible damage, leaks, or loose parts on the exterior of the reach stacker.

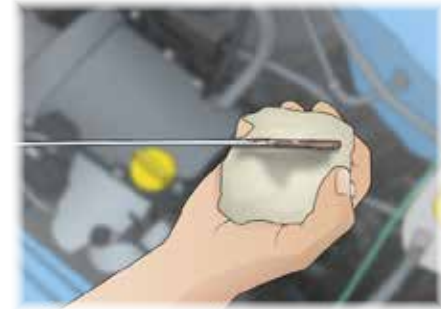

Fluid Levels:

Check engine oil, hydraulic fluid, coolant, and fuel levels. Top up if necessary.



Tyre Inspection:

Inspect all tyres for proper inflation, damage, or excessive wear. Check that they are safe and legal.

Note: Low pressure can affect stability.



Controls and Instruments:

Ensure all controls, gauges, and instruments are functioning properly. Test the horn, lights (including headlights, indicators, and brake lights), wipers, and any other electrical components

Pre-start checks continued...

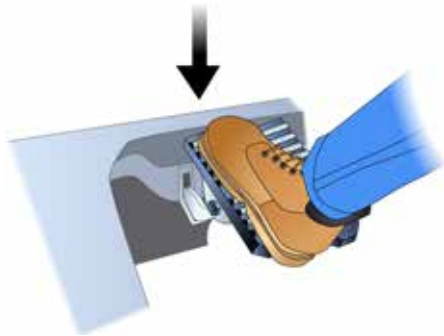
**Brakes:**

Test the brake pedals to ensure they are responsive and not spongy.

**Steering:**

Test the steering wheel to ensure it turns smoothly and without excessive play.

**Hydraulic System:**

Check hydraulic hoses and connections for leaks or damage.

**Safety Devices:**

Check that all safety devices, such as seat belts and mirrors, are in good condition and functioning correctly.

Pre-start checks continued...



Signage:

Check that you can read signage on the reach stacker such as rated capacity and the data plate.



Safety tags:

Check that there are no safety tags on the reach stacker. Do not use the reach stacker if there are.

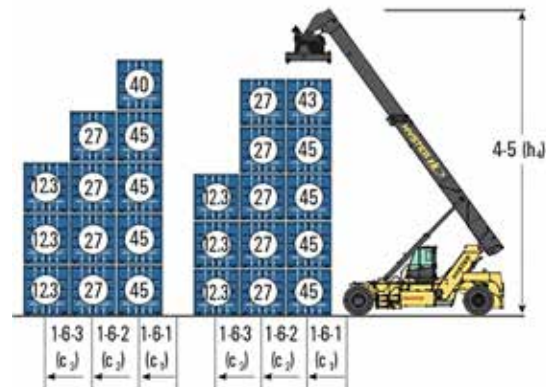

Load charts:

Check that you have load charts and that they are the right ones for the reach stacker that you are using. Load charts tell you how much you can lift (capacity and capabilities).

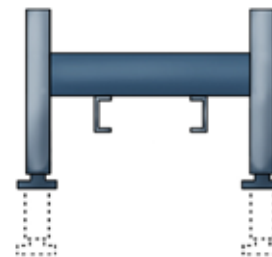

Stabilisers:

Check stabilisers if fitted.

Operational checks continued...



Limit switch:

Limit switches can be used to detect when the boom has reached its maximum extension or when the spreader has reached its maximum reach.



Travel limit:

A travel limit on a reach stacker refers to the maximum distance or range that the reach stacker can travel safely.

Operational checks continued...

Weight limit sensor:

When the weight detected by the sensor approaches or exceeds the predefined limit, the sensor triggers an alert or automatically activates safety mechanisms to prevent overloading.

Limit sensors:

Limit sensors can be used to limit height, boom angle, outrigger extension and load weight of the reach stacker.



Reverse alarm:

Reverse alarms warn other people or machines that the reach stacker is reversing. Reverse cameras help the operator to see behind the reach stacker when reversing.



Seat belts:

Seat belts protect the operator in the event of sudden stops, collisions, or tip-overs.

Operational checks continued...

The spreader has a number of parts which should be checked before operating the reach stacker. These include:

- **Compliance plate** - Tells you the manufacturer, model, serial number and capacity ratings.
- **Lifting lugs** - Are typically used for attaching lifting slings or hooks to facilitate the lifting and handling of the machine.
- **Twist locks** - Twist locks on a reach stacker are mechanisms used to securely lock shipping containers onto the spreader bars of the reach stacker.
- **Spreader** - The primary function of the spreader is to securely grasp and lift shipping containers from the top corner fittings.
- **Side shift** - AA side shift on a reach stacker refers to a feature that allows the operator to move the entire carriage or attachment horizontally along the length of the reach stacker's boom or mast. This capability enables the operator to adjust the position of the load relative to the reach stacker, providing more precise placement and alignment during handling operations.
- **Tilt cylinder** - A tilt cylinder on a reach stacker is a hydraulic component that is responsible for controlling the tilting motion of the reach stacker's attachment, typically the spreader or forks.
- **Rotating device** - A allows the operator to rotate the entire spreader assembly, including the attached container or cargo, horizontally around a vertical axis.



Operational checks continued...

Check that the reach stacker's computer / visual display is working accurately. You can do this by:

- Check the load against a know weight.
- Follow the manufacturer's specifications for pre-operational testing.
- Compare the computer results compared to the load chart.





Reporting and recording faults (pre-start)

If you notice any faults, damage, or defects during the pre-start checks you must take the appropriate action.

As the operator you are not allowed to perform any repairs on the reach stacker unless:

- You are competent (have the skills) to make the repair
- You have authorisation (permission from the appropriate person) to make the repair.

The correct action to take is:

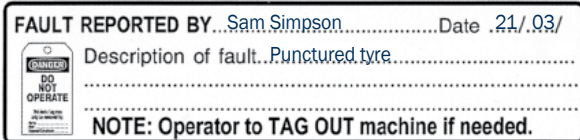
<p>1. Do not operate. Isolate the reach stacker by taking out the key.</p> 	<p>2. Tag the machine out of service.</p> <p>Note: The tag can only be removed when the reach stacker is deemed to be safe by a competent person.</p> 
<p>3. Report the problem to your supervisor.</p> <p>If you think the reach stacker has been tampered with report this.</p> 	<p>4. Write the problem in the logbook.</p> 
<p>Note: Always follow workplace policies and procedures and manufacturer’s instructions for maintaining and repairing plant and equipment.</p>	

Check for stability

You need to make sure that the reach stacker maintains its balance and resists tipping over or becoming unstable during operation. To do this you need to make sure:

- the cargo being lifted is evenly distributed across the reach stacker's chassis and lifting mechanism.
- maintain the center of gravity of the reach stacker and its load within the prescribed limits
- you follow correct operating procedures and techniques to minimise the risk of sudden movements or shifts that could destabilise the reach stacker.
- you consider factors such as wind, ground conditions, and slope of the terrain, which can affect the stability of the reach stacker.
- you regularly maintain and inspect the reach stacker's components, including its hydraulic systems, brakes, and tyres, to ensure optimal performance and stability.



Check the logbook

For example:

- Make sure you have the right logbook for the reach stacker you are using.
- Make sure the logbook is up to date and signed off.
- Make sure any jobs needed have been done.
- Make sure daily checks have been done.
- Make sure registration/compliance/certification is current.
- The owner of the reach stacker is recorded.
- Servicing and scheduled maintenance is carried out.
- Make sure the jobs follow the manufacturer's requirements and safe work procedures.



Maximum wind velocity

You should know the safe maximum wind velocity in which your reach stacker can work. These include:



In the reach stacker cabin (on decals).

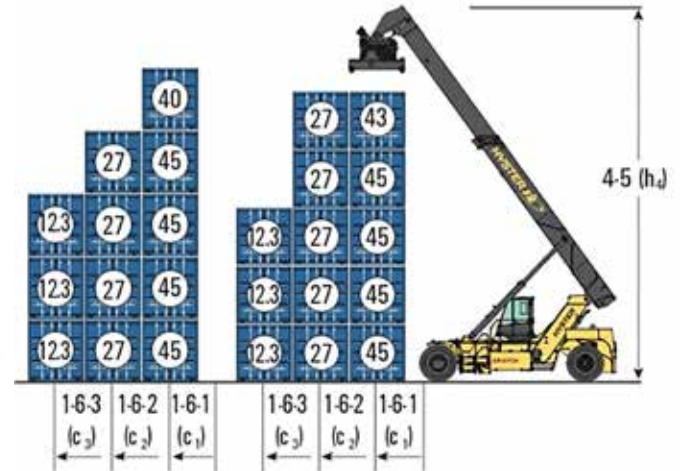

In the load chart.

Make sure the stack is safe and stable

When stacking containers you should consider the following:

- make sure the ground is stable
- the ground is stable
- the corner castings are aligned
- the containers are stacked square
- wind conditions.



Don't lift loads over people

Lowering loads over people could risk serious injury or death.

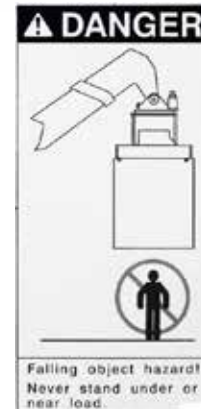

Drive safely to the work area

You need to safely drive to the work area in a way that ensures the safety of the operators, other workers, and the surrounding environment. You need to plan BEFORE you start operating in a particular area.

When working out the path of your reach stacker you should consider the following:

- the distance, speed and direction of travel
- stopping others going on the pathway
- how you will communicate with the spotter / guide
- overhead electric lines
- any obstructions
- the pickup and landing sites
- the size of the reach stacker
- the mass / size of the load.



CHAPTER 3

PERFORM WORK/TASK

Position container spreader over container

Position container spreader over container following directions from associated personnel (if applicable) in accordance with safe work procedures.

You need to make sure that:

- the twist locks align with the corner castings.
- you prevent damage to the container or spreader.



Note: Twist locks are a type of mechanism used in container handling equipment, including reach stackers. They are designed to securely attach containers to the equipment

Latch container spreader onto container

Container spreader is latched onto container and reach stacker is stabilised appropriately in accordance with safe work procedures



Align the corner castings when stacking containers because:

- the container wall may collapse if you don't.
- the corner castings provide structural support for the container.

Do a test lift

There are a number of reasons you should do a test lift. These include:

- to make sure the load is stable.
- to make sure the load is secure.
- to make sure the reach stacker is stable.
- to make sure the reach stacker's controls are working properly.
- to check that the load is the right weight.



Finding a problem when you do a test lift

If you find a problem when doing a test lift you should lower the load and fix the problem. Do not continue until the problem has been fixed.



Using an articulated reach stacker

Some reach stackers are articulated. Operators should be aware of the maximum angle of articulation allowed for the reach stacker. Exceeding these limits can lead to tip-over accidents or damage to the equipment.

Braking too hard or too quickly

If you brake too hard or too quickly with a load the reach stacker could tip over.



Tipping over

Turning too quickly or too sharply can cause the reach stacker to tip over. To prevent this you should:

- make sure the container is being carried according to the operator's manual.
- slow down.
- turn the wheel slowly.
- turn smoothly and evenly.



Note: Typically, the maximum speed of a reach stacker ranges from around 15 to 25 kilometers per hour. This speed is sufficient for maneuvering within container terminals, loading and unloading containers, and moving between stacking areas.

CHAPTER 4

PACK UP

Leaving the cabin

Before leaving the cabin you should:

1. Stop the reach stacker on flat ground.
2. Lower the load.
3. Disengage the load.
4. Put the directional controls into neutral.
5. Put on the parking brake.
6. Turn off the engine and controls.
7. Take out the key.



Secure the boom and container spreader

Here are some steps to follow:

1. Park the reach stacker on level ground and engage the parking brake.
2. Stow the spreaders if applicable, and lower the boom.
3. Engage any locking mechanisms for the boom.
4. Use safety chains or straps to further secure the boom and spreader.
5. Inspect for stability and ensure all locking mechanisms are engaged.
6. Follow manufacturer guidelines and document procedures for securing.

